

RF7C-E30 Photoluminescent Resilient Flooring Nosing

The **RF7C-E30** Photoluminescent Anodized Resilient Nosings are designed to be installed flush with resilient flooring. It provides step edge visibility and enhances egress speed in all light conditions. The RF7C-E30 has an 85 degree angle.

Engineered for Durability

- Manufactured using Ecoglo's patented process which produces the most durable and highly efficient photoluminescent product available.
- Unique ridges in the photoluminescent strips protect it from most abrasive wear. They provide slip resistance while still allowing the product to be easily cleaned.
- The hard-wearing silicon carbide non-slip material is integrally bonded to the aluminum substrate. Thousands of people can walk on it with no signs of wear and tear.
- The thick anodized finish is aesthetically pleasing, prevents corrosion, and is extremely hard and abrasion resistant. The anodized aluminum surface is harder than pure aluminum, second only to diamonds hard crystalline structure.

For Indoor Use and Outdoor Use

- Tested to accelerated UV/weathering exposure, and proven to be highly resistant to the effects of UV/weathering.
- The loss in performance is less than can be detected by the human eye when subjected to 6000 hours of UV exposure, which is similar to 30 years of outdoor exposure.
- The polymer used in Ecoglo's patented process is "long chain" which forms a strong UV resistant product when bonding.

Step Edge Safety

- The colour contrasting the non-slip material with advanced photoluminescent technology provides step edge visibility in all light conditions.
- The unique ridges in the Ecoglo[®] photoluminescent strips and the integrated anti-slip contrast strips provide all-weather slip resistance.

Aluminum Finish

- Available in Clear Anodized Aluminum Finish
- Black, Light Bronze and, Dark Bronze Anodize finishes are available at an additional cost

Environmentally Friendly

- LEED points qualified
- Zero energy consumption
- Non-Radioactive and Non-toxic
- Recyclable; No disposable cost

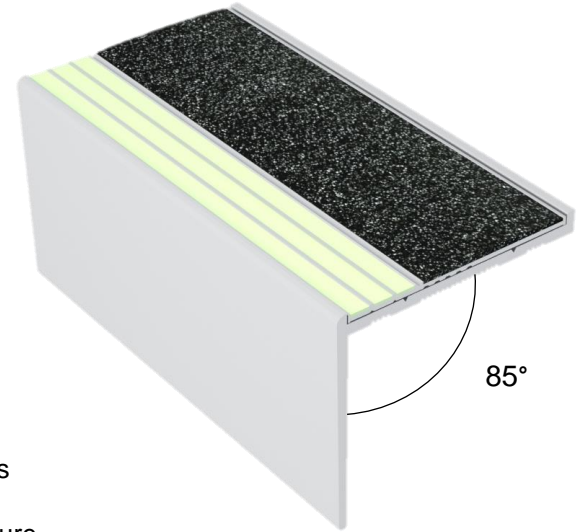

Product Colours

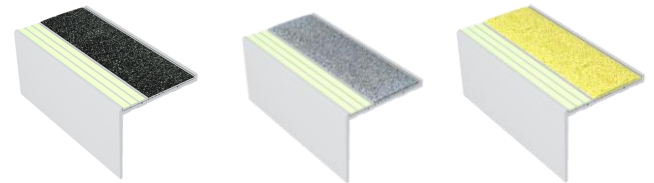

Black

Grey

Yellow

RF7C171

RF7C161

RF7C151

Product Dimensions

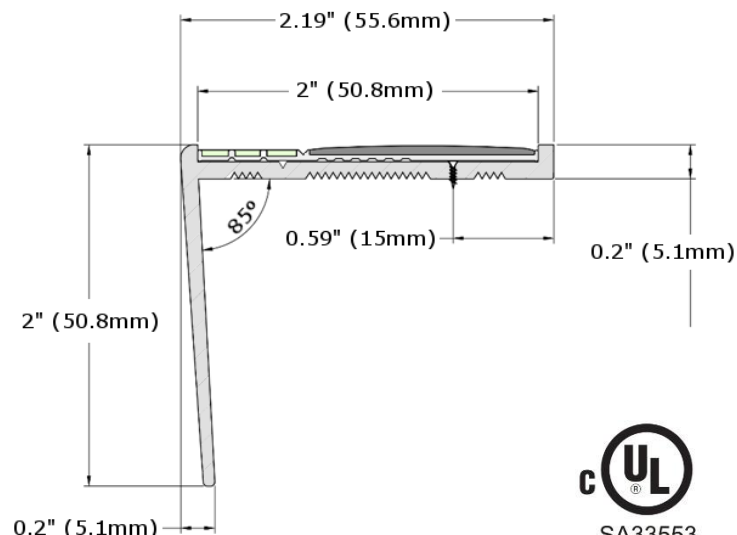

**UL 1994 AND
ULC 572 Listed**

RF7C-E30 Photoluminescent Resilient Flooring Nosing

The Ecoglo RF7C-E30 meets the following Building, Accessible Design, Fire & Life Safety Codes:

- IBC/IFC 2009, 2012 (Section 1024-Luminous Egress Path Markings) and 2015-2021 (Section 1025)
- ULC 590 S
- ULC 572 S
- CSA B651
- ISO/FDIS 2145

Qualifies for LEED Points

MR Credit 2: Construction Waste Management Divert from Land Fill

- Products are Aluminum based and 100% recyclable.

MR Credit 4: Recycled Content

- Products are Aluminum based and approximately 20% of the aluminum content in an Ecoglo secondary billet specification is recycled scrap.

Ecoglo's Recommended Installation Adhesive has low VOC's and qualifies for Indoor Environmental

Quality credits for low emitting materials: EQc4.1

General Information

- Install flush with resilient flooring using adhesive and mechanical fasteners
- Countersunk pre-drilled holes. Includes stainless steel fasteners and concrete nylon anchors. Standard location is 2" from each end and approx. 12" apart.
- Available in cut to length sizes. (Tolerance +or- 1/8") Standard lengths are 8ft and 10ft.
- Inserts are supplied unattached. Inserts are installed over the mechanical fasteners using a polyurethane adhesive (included). Inserts can be cut using a shear. Aluminum nosings are cut with a saw. Cutting inserts with saw will damage the saw blade.
- Weight: 0.586 lbs/ft.

Benefits and Technical Details: Ecoglo RF7C-E30 meets or exceeds the performance criteria specified in the following tests or standards:

Brightness

High visibility in dark or light conditions.

- ASTM E2073-02, Standard Test Method for Photopic Luminance of Photoluminescent (Phosphorescent) Markings.
- DIN 67510 Part 1, Phosphorescent Pigments and Products: Measurement and identification by the manufacturer.
- ISO 17398:2004 Clause 7.11, Safety Colours and Safety Signs- Classification, Performance and Durability of Safety Signs.

UV Stability

High durability indoors and outdoors.

- ASTM G155-04 Cycle 1 2000hrs, Standard Practice for Operating Xenon Arc Light Apparatus for Exposure of Nonmetallic Materials.
- Salt Spray Resistance: ASTM B117-97 500hrs, Standard Practice for Operating Salt Spray (Fog) Apparatus.
- Freeze-Thaw Resistance: ASTM C1026-87(1996), Standard Test Method for Measuring the Resistance of Ceramic Tile to Freeze-Thaw Cycling

Slip Resistant

Reduces slips.

- UL410, Standard for Slip Resistance for Floor Surface Materials.
- AS/NZS 4586-1999, Slip Resistance Classification of New Pedestrian Surface Materials.

Abrasion Resistance

Hard wearing.

- ASTM D1242-95a, Standard Test Methods for Resistance of Plastic Materials to Abrasion.
- ASTM B 244-97, Test Methods for Measurement of Anodic Coatings on Aluminum and other Nonconductive Coatings on Nonmagnetic Basis Metals with Eddy-Current Instruments.
- ASTM B137-95(2000), Test Method for Measurement of Coating Mass per Unit Area of Anodically Coated Aluminum.
- ASTM F510-93(2004), Standard Test Method for Resistance to Abrasion of Resilient Floor Coverings Using an Abrader with a Grit Feed Method.
- JIS H8682-1:1999, Test methods for abrasion resistance of anodic oxide coatings on aluminum and aluminum alloys- Wheel wear test.

Washability

Easy Cleaning.

- ASTM D4828-94(2003), Standard Test Methods for Practical Washability of Organic Coatings.
- ASTM B136-84(1998), Standard Test Method for Measurement of Stain Resistance of Anodic Coatings on Aluminum.

Radioactivity

No radioactivity or toxicity.

- ASTM D3648-2004, Standard Practices for the Measurement of Radioactivity.
- Toxicity: Bombardier SMP 800-C (2000), Toxic Gas Generation Test.

Flammability

Does not burn.

- ASTM E162-02, Standard Test Method for Surface Flammability of Materials Using a Radiant Heat Energy Source.
- ASTM D635-03, Standard Test Method for Rate of Burning and/or Extent and Time of Burning of Plastics in a Horizontal Position.
- FAA AC 23.2 Paragraph 4.b, Horizontal Burn Test.

Contact Ecoglo Inc. for a quick quote or to obtain more information about our emergency lighting products.

Made in USA

KINESIK Engineered Products Incorporated

2213 North Sheridan Way
Mississauga, Ontario L5K 1A3
Canada

Phone: 855.364.7763
Fax: 800.769.4463
www.kinesik.ca