

Melt Your Problems Away

The **ProMelt® Smart Controller** operates hydronic and electric heating equipment designed to melt snow and ice from roads and walkway surfaces. The control works with the Snow/Ice Sensor 090 or Snow Sensor 095 to automatically detect snow or ice and operates a single boiler, steam valve, or electric cable to supply heat to the slab.



Works with the
Watts® Home Mobile App



Safe and Convenient Snow Removal

Features:

- Automatic snow/ice detection
- Compatible with inslab & retrofit aerial sensors
- Tandem snow/ice detection
- Operates hydronic or electric on/off systems
 - Supports multiple zones with priority
 - Warm weather shut down
 - Cold weather cut off
 - Idling and manual storm for quick response
 - System pump exercising

ProMelt Smart Controller

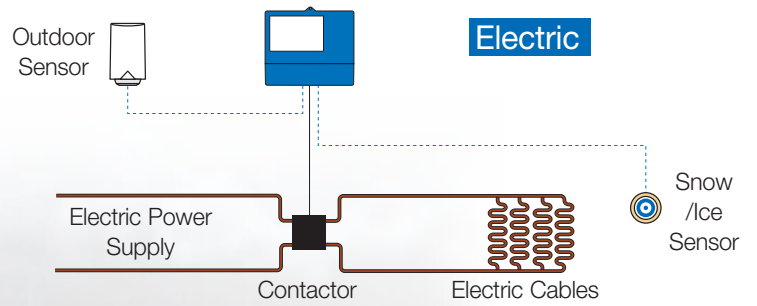

ProMelt Smart Controller

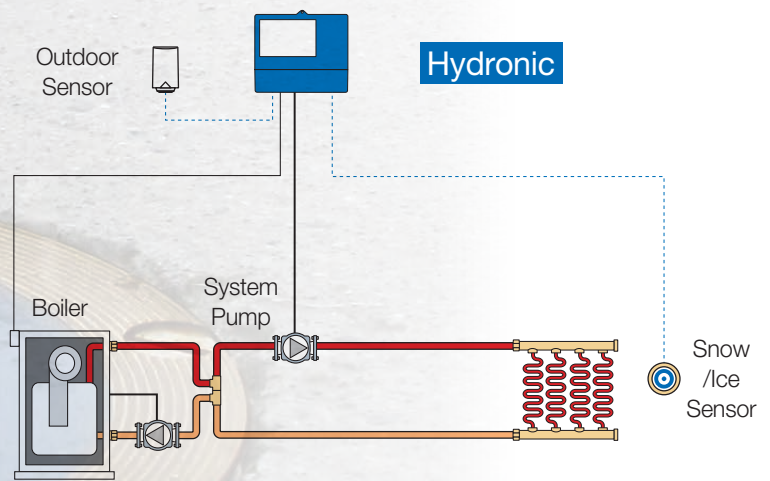

ProMelt Smart Controller

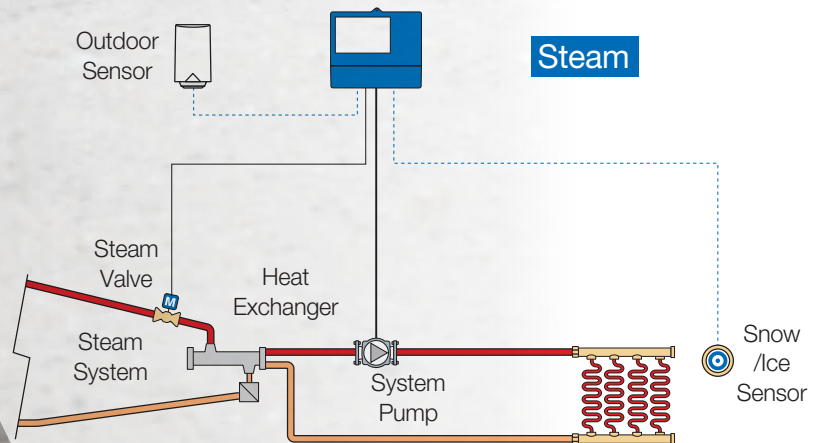

Scan to learn more about ProMelt Smart Controller

